

# 594 TITAN

## HYDRAULIC PRESSURE TEST PUMP

MAY 1, 2013  
 SUPERSEDES ALL  
 PREVIOUS

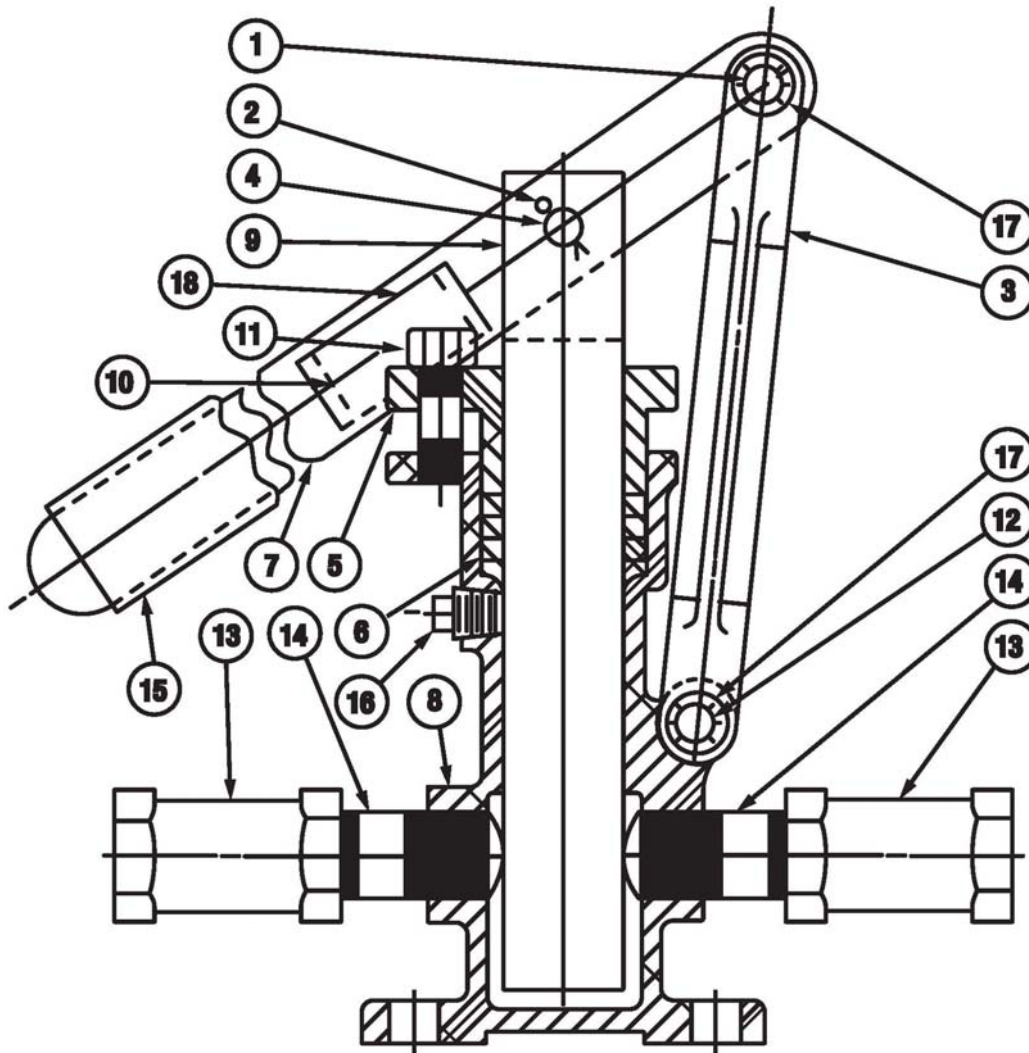

594 TITAN

Item No.	Part Number	Qty / Pump	Description
1	01-0046125	1	Lever Pin—Steel—3/8" x 1-3/4"
2	02-0000986	2	Cotter Pin
3	03-0008257	1	Lever Link—Cast Iron
4	04-0008235	1	Plunger Pin—Steel
5	05-0008270	1	Packing Gland—Cast Iron
6	06-0008272	5	Gland Packing
7	07-0044073	1	Lever with Drilled Holes
8	08-0008273	1	Cylinder—Cast Iron
9	09-0008275	1	Plunger—Cold Rolled Steel
10	10-0001146	2	Drive Screw
11	11-0000434	2	Hex Hcl Cap Screw
12	12-0046124	1	Link Pin—Steel—3/8" x 2"
13	13-0081647	2	3/4" Check Valve
14	14-0000984	2	3/4" x 2" Nipple—Galv.
15	15-0026677	1	Handel Grip
16	16-0000019	1	Pipe Plug—1/4" Brass
17	17-0039905	4	Push Nut
18	18-0000011	1	Name Plate

PLEASE ORDER BY PART NUMBER

SUBJECT TO CHANGE WITHOUT NOTICE

### Recommended Procedure to Change out Packing on the 594 TITAN Hydraulic Pressure Test Pump

- 1) Disconnect Lever (7) from Plunger (9).
- 2) Remove Packing Gland (5) and set aside.
- 3) Remove all five rings of old packing (a picking tool or flat head screw driver works).
- 4) Clean any dirt or debris from the packing box housing area (a solvent works well).
- 5) Dry out the packing box housing with a clean cloth.
- 6) Install five each new rings of Gland Packing (6), P/N TI2 06-0008272.
  - a) Install each ring of packing so that the "joints" are offset 90 degrees from one another.
- 7) Reassemble pump in reverse order.

**Note:**

The plunger needs to be installed before installing new packing. This allows the packing to wrap around the plunger. The packing gland can be used to press the packing into the stuffing box.

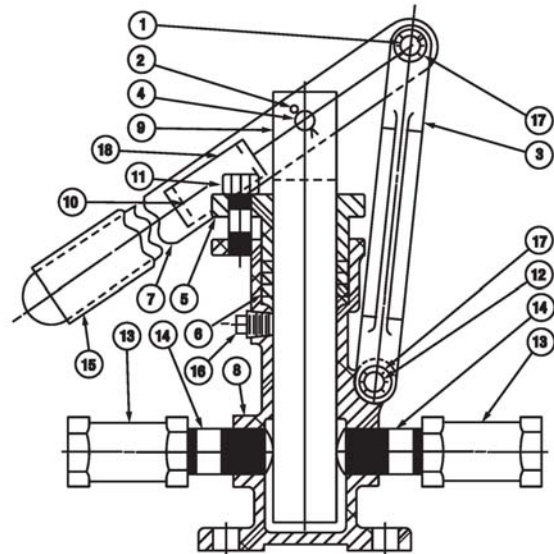

### LIMITED WARRANTY

Superior Titan Manufacturing Corp. (STM Corp) warrants its 594 TITAN Hydraulic Test Pump to be free of defects in parts and workmanship for a period of two (2) years from date of manufacture. Failures due to normal "wear and tear", misapplication, or abuse will be excluded from warranty coverage.

Product being claimed for warranty must be returned to the factory "freight prepaid". Contact your distributor for a "Return Authorization" number prior to shipment. Any pump being returned which has been handling chemicals, fuels, or any liquid other than fresh clean water, must be accompanied by the appropriate MSDS paperwork.

Product returned for warranty claim will be inspected by our warranty team and a decision will be made. Decisions made by STM Corp are at its sole discretion and are final. Repaired or replacement product will be shipped freight prepaid to the INCOTERMS point of the original sale.

STM Corp accepts no liability for extenuating charges relating to a pump's failure such as labor, time lost, damage to other equipment, etc. Any damage incurred to goods in transit must be handled with the corresponding carrier.